



**SUBMITTAL DATA – WALL-MOUNTED
LM012CO-130P433-E - LM012CI-130P433-E
SINGLE ZONE MINI-SPLIT COOLING ONLY**

Job: _____
Location: _____
Schedule No.: _____
System Designation: _____

Engineer: _____
Architect: _____
Date: _____

FEATURES

Outdoor Unit: LM012CO-130P433-E
Outdoor Unit Cat Number: 22F55

Indoor Unit: LM012CI-130P433-E
Indoor Unit Cat Number: 22F53



- 3 Meter Copper Pipe Included
- Gold Fin

- Auto Restart
- Wireless Remote
- Emergency Control
- Louver position memory
- Hidden LED Display
- I Feel

PIPING

Line Set and Elevation Guidelines	
Maximum Line Set Length ft. (m)	52.5 ft. (16 m)
Maximum Elevation - Outdoor Unit Below/Above Indoor Unit ft. (m)	16.4 ft. (5 m)
Liquid Line Set Diameter (in.)	1/4"
Gas Line Set Diameter (in.)	3/8"

PRODUCT WARRANTY

5 Year Limited Warranty*

OPTIONAL ACCESORIES



NOTE – Due to Lennox' ongoing commitment to quality, Specifications, Ratings, and Dimensions are subject to change without notice and without incurring liability. Improper installation, adjustment, alteration, service or maintenance can cause property damage or personal injury. Installation and service must be performed by a qualified installer and servicing agency



**SUBMITTAL DATA – WALL-MOUNTED
LM012CO-130P433-E - LM012CI-130P433-E
SINGLE ZONE MINI-SPLIT COOLING ONLY**

OUTDOOR SPECIFICATIONS

PERFORMANCE	
Cooling Capacity (Btu/h)	11,089
EER(W/W)	2.82
SEER(BTUH/W)	12.7
Heating Capacity (Btu/h)	/
COP	/
Outdoor Fan Total Air Volume (CFM) 1059	
Ambient Temperature Operating Range	
Cooling	64 °F(18°C) - 114 °F(43°C)
Heating	/
ELECTRICAL DATA	
Power Supply (V/Hz/ϕ)	208-230/60/1
Minimum Circuit Ampacity (A)	/
Maximum Overcurrent Protection (A)	/
Outdoor Fan Motor RLA (A)	0.39
Compressor RLA (A)	5.1
No. of Compressors	1

GENERAL DATA	
Connection Ratio (%)	100%
Max. # of Indoor Units	1
Sound Data (dBA) - Cooling/Heating	51
Refrigerant type	R-410A
Factory refrigerant charge	1.08 lbs. 17.28 oz.

DIMENSIONS		
Unit Dimensions (in)	Height	20
	Width	31
	Depth	11
Shipping Weight (lb)		62
Net Weight (lb)		55

NOTES
1. Cooling and Heating Capacity data is rated at the following conditions:
Cooling: 80 °FDB / 67 °FWB Indoor, 95 °FDB/75 °FWB Outdoor
Heating: 68 °FDB / 59 °FWB Indoor, 44.6 °FDB/ 42.8 °FWB Outdoor

OUTDOOR DIMENSIONAL DRAWINGS - INCHES (MM)

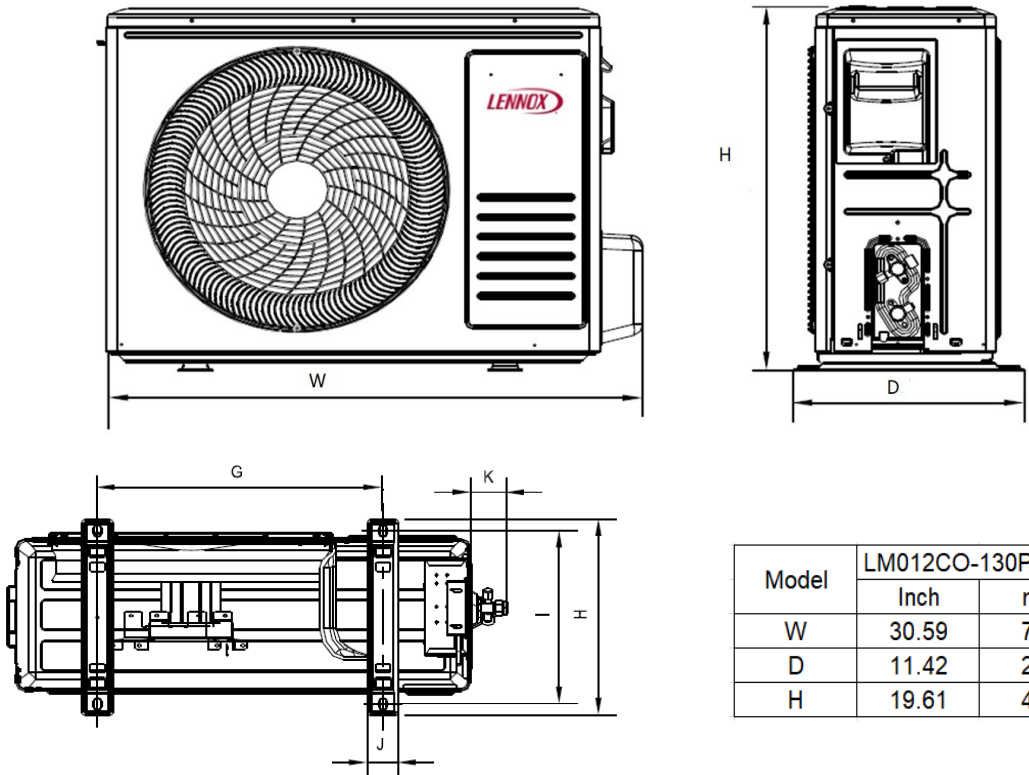

Model	LM012CO-130P433-E	
	Inch	mm
W	30.59	777
D	11.42	290
H	19.61	498

NOTE – Due to Lennox’ ongoing commitment to quality, Specifications, Ratings, and Dimensions are subject to change without notice and without incurring liability. Improper installation, adjustment, alteration, service or maintenance can cause property damage or personal injury. Installation and service must be performed by a qualified installer and servicing agency



**SUBMITTAL DATA – WALL-MOUNTED
LM012CO-130P433-E - LM012CI-130P433-E
SINGLE ZONE MINI-SPLIT COOLING ONLY**

INDOOR SPECIFICATIONS

PERFORMANCE		
Airflow (CFM)	Turbo	/
	High	265
	Medium	247
	Low	230
External Static Pressure (in. w.g.)		-
Sound Pressure (dBA)	Turbo	/
	High	40
	Medium	37
	Low	34

ELECTRICAL DATA

Power Supply (V/Hz/φ)	208-230/60/1
Rated load amps (RLA)	0.21
Power Output (W)	13

DIMENSIONS

Unit Dimensions (in)	Height	8
	Width	31
	Depth	10
Unit Net/Shipping Weight (lb)		18/22

WIRELESS REMOTE CONTROLLER SPECIFICATIONS

23C82	
Power Supply	2 AAA Batteries (Included)
Setpoint Range	61°F(16°C) - 88°F(31°C)
Effective Receiving Range	20 ft.(6m)

DISPLAY

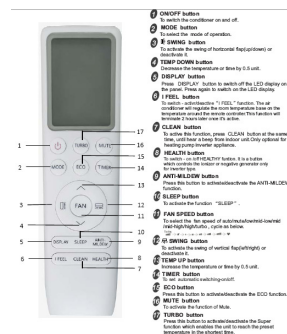

INDOOR DIMENSIONAL DRAWINGS - INCHES (MM)

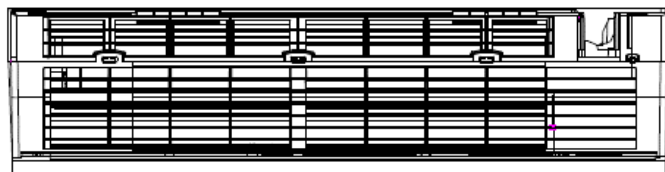
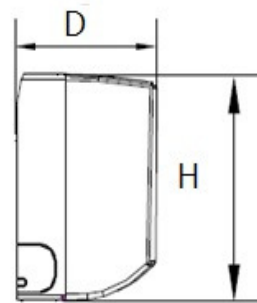
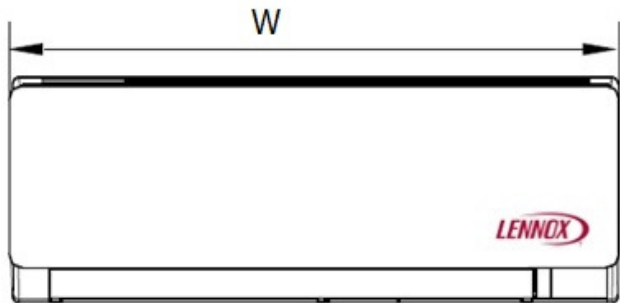

Model	LM012CI-130P433-E	
	Inch	mm
W	30.59	777
D	9.84	250
H	7.91	201

NOTE – Due to Lennox' ongoing commitment to quality, Specifications, Ratings, and Dimensions are subject to change without notice and without incurring liability. Improper installation, adjustment, alteration, service or maintenance can cause property damage or personal injury. Installation and service must be performed by a qualified installer and servicing agency